

# System 450™ Series Control Modules with Relay Outputs Installation Instructions

C450CBN-4  
C450CCN-4

Part No. 24-7664-3205, Rev. B  
Issued October 2018

Refer to the [QuickLIT website](#) for the most up-to-date version of this document.

## Application

**IMPORTANT:** Use this System 450™ Series Control Module with Relay Outputs only as an operating control. Where failure or malfunction of the System 450™ could lead to personal injury or property damage to the controlled equipment or other property, additional precautions must be designed into the control system. Incorporate and maintain other devices, such as supervisory or alarm systems or safety or limit controls, intended to warn of or protect against failure or malfunction of the System 450™.

**IMPORTANT :** Utiliser ce System 450™ Series Control Module with Relay Outputs uniquement en tant que dispositif de contrôle de fonctionnement. Lorsqu'une défaillance ou un dysfonctionnement du System 450™ risque de provoquer des blessures ou d'endommager l'équipement contrôlé ou un autre équipement, la conception du système de contrôle doit intégrer des dispositifs de protection supplémentaires. Veiller dans ce cas à intégrer de façon permanente d'autres dispositifs, tels que des systèmes de supervision ou d'alarme, ou des dispositifs de sécurité ou de limitation, ayant une fonction d'avertissement ou de protection en cas de défaillance ou de dysfonctionnement du System 450™.

System 450™ is a family of modular, digital electronic controls that is easily assembled and set up to provide reliable temperature, pressure, and humidity control for a wide variety of HVACR and commercial and industrial process applications.

The System 450 control modules allow you to configure custom application-specific control systems with up to three input sensors and ten (relay, analog, or both) outputs, including control systems that can monitor and control temperature, pressure, and humidity applications simultaneously.

You can easily install and quickly configure a stand-alone System 450 control module and sensor in the field as a replacement control for almost any temperature, pressure, and humidity control.

C450CBN-4 and C450CCN-4 models are relay output control modules with LCD and four-button touchpad user interface (UI) that allows you to set up a System 450 control system. C450CBN-4 models provide one relay output, and C450CCN-4 models provide two relay outputs.

Refer to the *System 450™ Series Modular Control Systems with Standard Control Modules Technical Bulletin (LIT-12011459)* for more detailed information on designing, installing, setting up, and troubleshooting System 450 Series control systems. The System 450 technical bulletin can be accessed and downloaded on the Johnson Controls® *QuickLIT* Product Literature website.



## Installation

**Figure 1: System 450 Module Dimensions, mm (in.)**

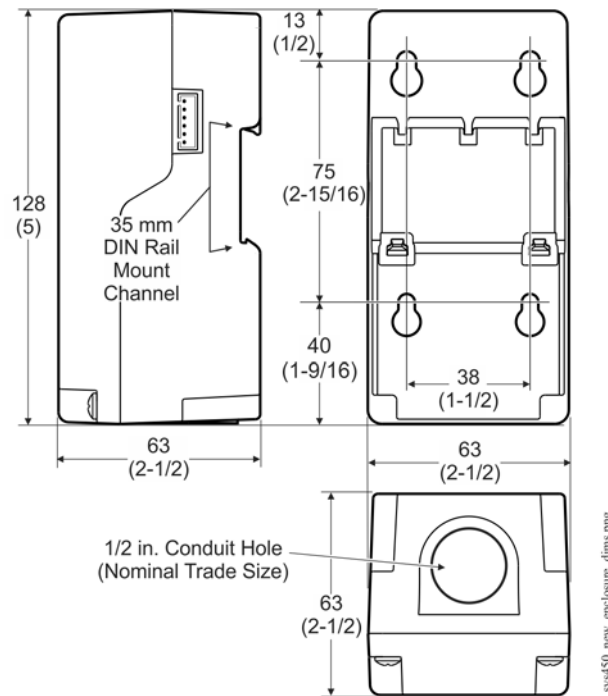

### **Location Considerations**

Observe the following System 450 location guidelines:

- Ensure that the mounting surface can support the module assembly, mounting hardware, and any (user-supplied) panel or enclosure.
- Mount the modules upright and plugged together in a horizontal row where possible (Figure 3). DIN rail mounting is highly recommended.
- Mount modules on flat, even surfaces.
- Allow sufficient space for wires and connections.
- Mount the modules in locations free of corrosive vapors and observe the ambient operating conditions listed in the *Technical Specifications* on page 28.
- Do not mount the modules on surfaces that are prone to vibration or in locations where radio frequency or electromagnetic emissions may cause interference.
- Do not install the modules in airtight enclosures.
- Do not install heat-generating devices in an enclosure with the modules that may cause the temperature to exceed the ambient operating limit.

### **Mounting**

Mount System 450 modules on 35 mm DIN rail (recommended) or directly onto an even wall surface. To mount modules on DIN rail:

1. Provide a section of 35 mm DIN rail that is longer than the module assembly width, and mount the DIN rail horizontally in a suitable location using appropriate mounting hardware or fasteners.
2. Clip the control module on the rail, position the upper DIN rail clips on the top rail, and gently snap the lower clips onto the rail.

3. Clip the remaining power and expansion modules to the right of the control module on to the DIN rail and plug the 6-pin module connectors together (Figure 3).

**Notes:**

- DIN rail end clamps can be used to prevent the module assembly from sliding off the DIN rail.
- If your System 450 control system uses a power module, the power module **must** be plugged into the right-hand side of the control module.

To direct-mount modules to wall surfaces:

1. Plug the modules together, remove the module covers, place the assembly against wall surface horizontally in a suitable location, and mark the mount hole locations on the surface (Figure 1).
2. Install appropriate screw fasteners, leaving screw heads approximately one to two turns away from flush to the surface.
3. Place the assembly over screw heads on the mounting slots, and carefully tighten the mounting screws.

**Note:** If you mount the modules on an uneven surface, do not damage the housings when tightening mounting screws. Use shims or washers to mount the module assembly evenly on the surface.

Refer to the control sensor installation instructions for information on locating and mounting control sensors.

**Wiring**

See Figure 2 and Table 1 for electrical termination locations and wiring information. See *Technical Specifications* on page 28 for electrical ratings.

**⚠ WARNING**

**Risk of Electric Shock.**

Disconnect or isolate all power supplies before making electrical connections. More than one disconnection or isolation may be required to completely de-energize equipment. Contact with components carrying hazardous voltage can cause electric shock and may result in severe personal injury or death.

**⚠ AVERTISSEMENT**

**Risque de décharge électrique.**

Débrancher ou isoler toute alimentation avant de réaliser un branchement électrique. Plusieurs isolations et débranchements sont peut-être nécessaires pour -couper entièrement l'alimentation de l'équipement. Tout contact avec des composants conducteurs de tensions dangereuses risque d'entraîner une décharge électrique et de provoquer des blessures graves, voire mortelles.

**IMPORTANT:** Use copper conductors only. Make all wiring connections in accordance with local, national, and regional regulations.

**IMPORTANT:** Do not exceed the System 450 module electrical ratings. Exceeding module electrical ratings can result in permanent damage to the modules and void any warranty.

**IMPORTANT:** Run all low-voltage wiring and cables separate from all high-voltage wiring. Shielded cable is strongly recommended for input (sensor) and analog output cables that are exposed to high electromagnetic or radio frequency noise.

**IMPORTANT:** Electrostatic discharge can damage System 450 modules. Use proper Electrostatic Discharge (ESD) precautions during installation and servicing to avoid damaging System 450 modules.

**IMPORTANT:** Do not apply power to a C450Y Power Module or the 24 VAC/VDC power source for the System 450 modules before finishing wiring and checking all wiring connections. Short circuits or improperly connected wires can result in damage to the modules and void any warranty.

**IMPORTANT:** A System 450 control module and module assembly can be connected to an internal power source (a System 450 power module) **or** an external power source (24 VAC/VDC power connected to the 24 V and COM terminals on the control module), but must **not** be connected to both power sources simultaneously. Connecting a control module to both internal and external power sources can damage the modules and void any warranty.

**IMPORTANT:** When connecting System 450 compatible sensors with shielded cable to a System 450 control module, connect the cable shield drain lead to one of the C (common) terminals on the input sensor terminal block. Do not connect the shield at any other point along the cable. Isolate and insulate the shield drain at the sensor end of the cable. Connecting a cable shield at more than one point can enable transient currents to flow through the sensor cable shield, which can cause erratic control operation.

**Figure 2: C450CxN-4 Wiring Terminals**

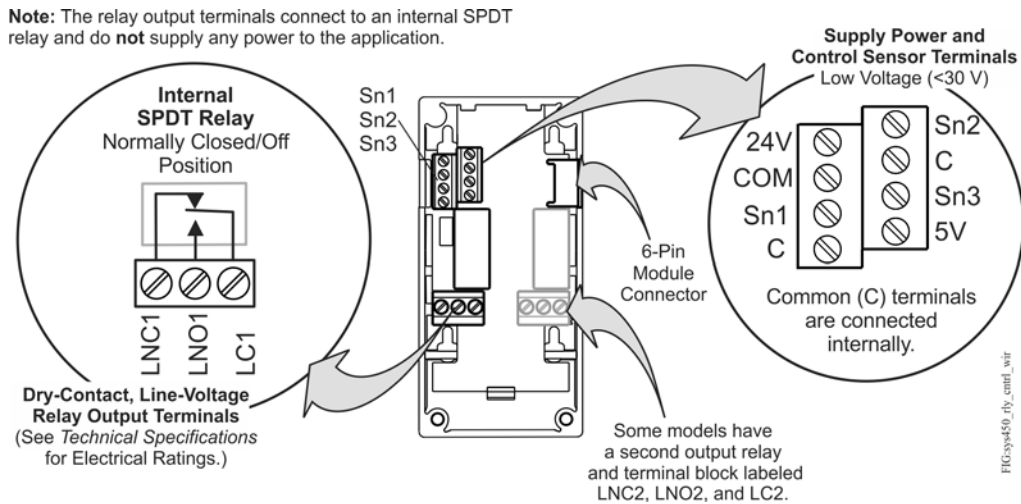

**Table 1: System 450 Relay Output Control Module Terminal Wiring Information**

Label	Terminal Function	Wire Sizes
24V	Accepts 24 VAC/VDC supply power when a C450YNN power module is <b>not</b> connected, and provides a power terminal for 24 V sensors.	0.08 mm <sup>2</sup> to 1.5 mm <sup>2</sup> 28 AWG to 16 AWG
5V	Provides 5 VDC power for active sensors.	
Sn-1, Sn-2, Sn-3	Accepts passive or active (0–5 VDC) input signals from control sensors. The control automatically selects a passive or active sensor circuit for each input based on the sensors selected in the setup screens.	
COM	Provides a connection for the 24 VAC/VDC supply common input.	
C (Two Terminals)	Provides low-voltage circuit Common connections for passive or active sensors that are connected to the 5V, Sn1, Sn2, and Sn3 terminals.	0.08 mm <sup>2</sup> to 2.5 mm <sup>2</sup> 28 AWG to 14 AWG
LNC1, LNC2	Connects the control circuit to the Line Normally Closed (LNC) contact on the single-pole, double-throw (SPDT) relay.	
LNO1, LNO2	Connects the control circuit to the Line Normally Open (LNO) contact on the SPDT relay.	
LC1, LC2	Use to connect Line (power) to the Common terminal on the SPDT relay.	

**Figure 3: System 450 Heat/Cool System with Condenser Fan Speed Control Example**

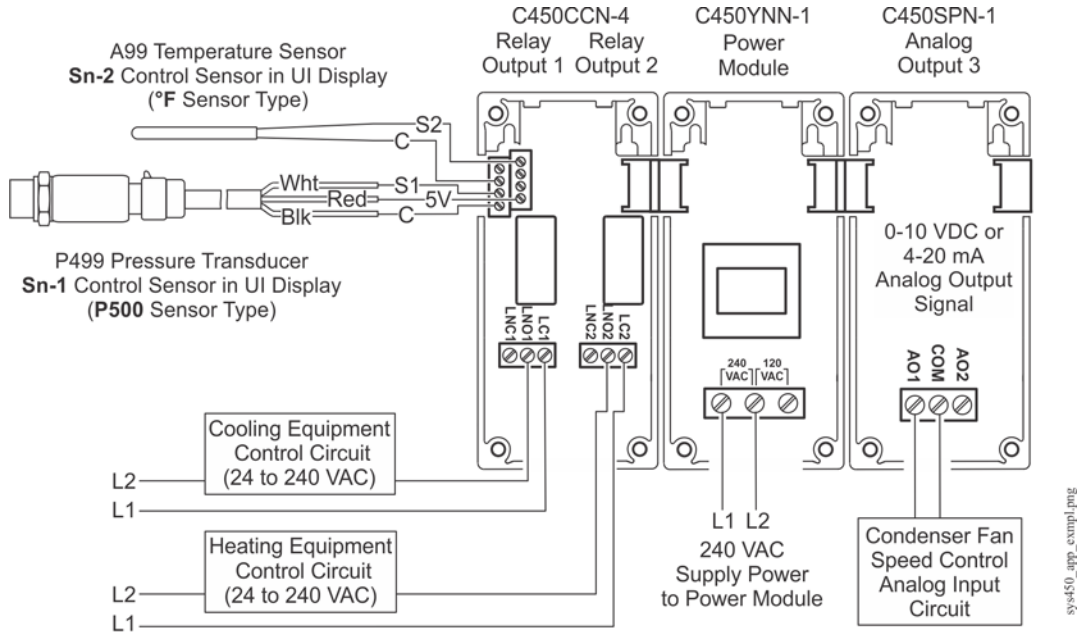

**Note:** In 120 VAC applications, L1 wire is connected to L2 terminal and Common wire must be connected to the COM terminal.

## Setup and Adjustments

### System 450 Component Requirements

A System 450 control system consists of one control module, one to three control sensor inputs, and one to ten outputs that provide On/Off control or analog control. Figure 3 shows an example System 450 module assembly with two sensors and three outputs (two analog outputs and one relay output).

### Setting Up a System 450 Module Assembly

1. Determine the controlled conditions, sensor types, and value ranges that are required for your application, and select the appropriate System 450 sensor types.
2. Determine the number and type (relay or analog) of outputs required to control your application, and select the appropriate System 450 control module and expansion modules to provide the outputs.
3. Assemble the control and expansion modules in the proper order, starting with the control module on the left.

#### Notes:

- If you use a C450YNN-1 power module, it must be plugged into the control module. Plug in any expansion modules (for your control system) to the right of the power module.
- After you power on your module assembly, you can set up your control system in the control module UI before wiring the sensors or outputs to your assembly. If the sensors are set up in the UI but not connected, the LCD displays an SNF Sensor Failure.

### Setting Up a Control System in the User Interface

System 450 control modules have a backlit LCD and a four-button touchpad UI (Figure 4 and Table 2) that enable you to set up your control system. To set up a control system in the System 450 UI:

1. Build your control system module assembly and connect it to power. See [Setting Up a System 450 Module Assembly](#).

**Note:** Every time a module assembly is powered ON, the control module polls all of the modules to identify output type (relay or analog) and assigns a sequential output number (1 to 9 [0 = 10]) to each output starting with the control module output on the left. The output numbers identify each output's setup screens in the UI. (See Figure 4 and Table 2.)

2. Access the System 450 setup screens in the UI. See [Accessing the System 450 Setup Start Screens](#) on page 9.
3. Set up the control system inputs or sensors in the UI. See [Setting Up System 450 Sensors](#) on page 9.
4. Set up the control system outputs in the UI. See [Setting Up System 450 Outputs](#) on page 15.

**IMPORTANT:** Do not change the module positions after a System 450 control system is set up in the UI. System 450 control logic is set up in the UI according to the Sensor Types, the output types, and the output numbers. Changing modules or module positions in a module assembly that is already set up in the UI can change the output numbers, output types, and the setup values of the assembly outputs, which requires setting up the outputs again.

**Figure 4: System 450 Control Module Output Relay LEDs, LCD, Four-Button Touchpad User Interface**

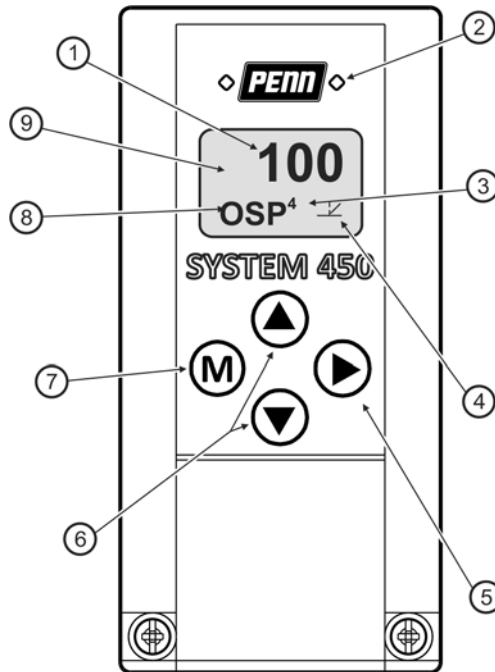

FIG: sys450\_ctrl\_module

**Table 2: System 450 Control Module Output Analog LEDs, LCD, Four-Button Touchpad User Interface**

Callout	Feature	Description
1	Status or Setup Value	Displays the current input status, output status, or setup parameter value for the displayed input sensor, output, or setup parameter. Press ▲ or ▼ to select a different parameter value when the value is flashing. (Here, 100 = 100%)
2	LED	Green LEDs on Relay Control Module and Relay Expansion Modules (only) indicate if the associated relay output is on or off.
3	Output Number	Displays a numerical value that identifies the output associated with the status or setup value shown on the screen. Output numbers are automatically determined by the outputs' physical positions (left to right) in the module assembly. (Here, 4 = Output 4)
4	Control Ramp Icon	Displays whether an analog output (only) is set as direct-acting or reverse-acting, and whether the output signal strength is at minimum or maximum when the sensed property is at Setpoint. The control ramp icon displayed is determined by the output's SP, EP, OSP, and OEP setup values.
5	Next Button	In the Main screens, press ▶ to scroll through the system status screens. In a setup screen, press ▶ to save the (flashing) setup value and go to the next setup screen.
6	Up and Down Buttons	Press ▲ or ▼ to select a different value for any flashing value in the setup value field. In the Main (sensor status) screens, press and hold both ▲ and ▼ for 5 seconds to access the setup Start screens.
7	Menu Button	Press ⏏ to move through the sensor and output setup start screens. When moving through the status or setup screens, press ⏏ to return to the status start screen or setup start screen.
8	Status or Setup Identifier	Displays the unit of measurement, output, sensor number, or setup parameter for the displayed status or setup value. (Here, the setup identifier OSP represents % output signal strength at setpoint.)
9	LCD	Backlit LCD screen. The LCD brightness is adjustable. During normal operation, the LCD displays the Main screens.

### Viewing the Startup, Main, and System Status Screens

Every time you connect power to a System 450 control module, the Startup screen appears for several seconds before the Main screens appear. The Startup screen displays the current firmware version for the module. See Table 3 and [System 450 Firmware Versions](#) for more information.













After you install, wire, power on, and set up your control system in the UI, the Main screens appear on the LCD, immediately after the Startup screen. During normal operation, the Main screens automatically scroll through the current status of each sensor in your control system and the backlight low level setting is applied. See Table 3 for more information.

The System Status screens display the current status of each input and output in your control system. With the Main screen displayed, press any key to exit idle mode, then press ▶ repeatedly to scroll through and view all of the status screens in your control system. See Table 3 for more information about the System Status screens.

### System 450 Firmware Versions

The System 450 firmware versions identify the control features that are available. Standard System 450 control modules with Version 2.00 firmware and later include the High Input-Signal Selection and Differential Control features. See [High Input-Signal Selection](#) on page 13 and [Differential Control](#) on page 14 for more information.

**Table 3: System 450 Startup Screen, Main Screens, Status Screens, and Setup Start Screens Information and Procedures**



LCD Screen	Name, Description/Function, User Action, and Example
	<p><b>Startup Screen:</b> When you power on a System 450 control module, the LCD displays the control module's current firmware version for approximately five seconds before it displays the Main (Input Status) screen. The screen example shows System 450 firmware version number <b>4.00</b> on the top of the screen. The number on the bottom of the screen (indicated in this example with xxxx) identifies the Johnson Controls firmware.</p>
	<p><b>Main (Input Status) Screens:</b> During normal operation, the Main screens automatically scroll through the current status of each input sensor in your control system and display the sensor number, the unit of measurement, and the sensed condition value.</p> <p><b>Note:</b> Main screens are view-only; selections are not made in Main screens. The Main screens are the System 450 default screens. After 2 minutes of inactivity in any screen, the UI returns to the Main screens.</p> <p><b>While the Main screens are scrolling, you can press  repeatedly to scroll through and view the System Status screens for all inputs and outputs in your control system.</b></p> <p><b>While the Main Screens are scrolling, you can press and hold  and  for 5 seconds to access your control system's Setup Start screens.</b></p> <p>The top two screen examples show <b>Sensor 1</b> sensing <b>70°F</b> and <b>Sensor 2</b> sensing <b>74°F</b>. The third screen example shows a <b>Temperature Differential Sensor</b> that is sensing a <b>-4</b> degree differential. The bottom screen shows <b>Sensor 3</b> set up as a <b>Binary Input</b> and the input is <b>open</b>.</p>
	<p><b>System Status Screens:</b> The System Status screens display the current status of all inputs and outputs in your control system. System Status screens are view-only. Relay output status screens display output number and relay status (On/Off). Analog output status screens display output number, signal strength, and control ramp icon.</p> <p><b>Press  repeatedly to scroll and view the System Status screens for the inputs and outputs in your control system. When you stop pressing , the displayed Status screen refreshes its value and remains displayed for 2 minutes before returning to the Main Screens.</b></p> <p>The screen examples show that the <b>Output 1</b> relay is <b>On</b> and the signal strength of <b>Output 3</b> is <b>61%</b> of the total signal strength. The control ramp icon in the bottom screen example indicates that the Analog Output is set up with SP&lt;EP and OSP&lt;OEP. See <a href="#">Setting Up an Analog Output</a> for information about ramp icons.</p>
	<p><b>Setup Start Screens:</b> Setup Start screens are view-only screens, from which you can access the setup screens for the sensors, the displayed output, or the backlight brightness. The Sensor Setup Start screen is the first screen displayed when you access the System 450 setup screens.</p> <p><b>Note:</b> The numerical order and type of Output Setup Start screens are determined by the modules that are selected for your System 450 control system and their physical order in the control system module assembly. See <a href="#">Setting Up a Control System in the User Interface</a> on page 5 for more information.</p> <p><b>From the Sensor Setup Start screen, press  repeatedly to scroll through the Output Setup Start screens for all of the outputs in your control system. When a Setup Start screen is displayed, press  to go to the setup screens for the sensors or the output displayed in the screen.</b></p> <p><b>Note:</b> In any Setup Start screen, you can return to the Main screens by pressing both  and  simultaneously. Also, the UI returns to the Main screen after 2 minutes of inactivity in any screen. The screen examples show the <b>Sensor, Relay Output 1, Analog Output 3, and LCD Backlight Brightness</b> Setup Start screens.</p>



## Accessing the System 450 Setup Start Screens

Access the System 450 Setup Start screens from the Main screen. See Table 3 for more information about the Setup Start screens.

To access the System 450 setup screens:

1. Power on the module assembly. After the **Startup** screen appears briefly (displaying the control module firmware version), the **Main** screen appears on the LCD.
2. With the **Main** screen displayed, press any key to exit idle mode, then press and hold  and  simultaneously for 5 seconds to access the setup screens and go to the **Sensor Setup Start** screen.
3. Press  repeatedly to scroll through the **Output Setup Start** screens. See Figure 6.

**Note:** The UI returns to the Main screens after 2 minutes of inactivity in any screen in the UI.

## Setting Up System 450 Sensors

You must set up the input sensors for your control system before you can set up any outputs. To set up the input sensors, you must access the setup screens.

The Sensor Setup Start screen is the first screen displayed when you access the system setup screens.

Table 4 provides information about System 450 sensors, Sensor Types, parameter values, and specified sensor or transducer product code numbers. Table 5 provides sensor setup information, procedures, and example screens. Figure 6 on page 26 provides a System 450 UI setup example.

**Table 4: System 450 Sensor Types, Setup Values, and Sensor or Transducer Product Codes (Part 1 of 2)**

Sensor Type	Unit of Measurement Code (Condition/Units)	Effective Sensing Range	Range of Usable Values <sup>1</sup>	Resolution Increment Value	Minimum Proportional or Control Band	Sensor Product Type Number <sup>2</sup>
°F	°F (Temperature/degrees)	-46 to 255	-40 to 250	1	1	A99x-xxx
°C	°C (Temperature/degrees)	-43 to 124	-40 to 121	0.5	0.5	A99x-xxx
rH	% (Humidity/%RH)	1 to 100	10 to 95	1	2	HE-67Sx-xxxxx HE-67Nx-xxxxx HE-68Nx-0N00WS
<b>P 0.25</b>	<b>INWC</b> (Pressure/in. W.C.)	-0.250 to 0.250	-0.225 to 0.250	0.005	0.01	DPT2650-R25B-AB
<b>P 0.5</b>	<b>INWC</b> (Pressure/in. W.C.)	0 to 0.5	0.025 to 0.5	0.005	0.01	DPT2650-0R5D-AB
<b>P 2.5</b>	<b>INWC</b> (Pressure/in. W.C.)	0 to 2.5	0.1 to 2.5	0.02	0.1	DPT2650-2R5D-AB
<b>P 5</b>	<b>INWC</b> (Pressure/in. W.C.)	0 to 5.0	0.25 to 5.0	0.05	0.25	DPT2650-005D-AB
<b>P 8</b>	<b>bAR</b> (Pressure/bar)	-1 to 8	-1 to 8	0.05	0.1	P499RCP-401C P598RCPSN401C
<b>P 10</b>	<b>INWC</b> (Pressure/in. W.C.)	0 to 10	0.5 to 10	0.05	0.2	DPT2650-10D-AB
<b>P 15</b>	<b>bAR</b> (Pressure/bar)	-1 to 15	-1 to 15	0.1	0.2	P499RCP-402C P598RCPSN402C
<b>P 30</b>	<b>bAR</b> (Pressure/bar)	0 to 30	0 to 30	0.1	0.4	P499RCP-404C P598RCPSN404C
<b>P 50</b>	<b>bAR</b> (Pressure/bar)	0 to 50	0 to 50	0.2	0.4	P499RCP-405C P598RCPSN405C

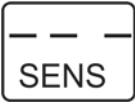

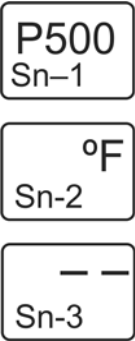









**Table 4: System 450 Sensor Types, Setup Values, and Sensor or Transducer Product Codes (Part 2 of 2)**

Sensor Type	Unit of Measurement Code (Condition/Units)	Effective Sensing Range	Range of Usable Values <sup>1</sup>	Resolution Increment Value	Minimum Proportional or Control Band	Sensor Product Type Number <sup>2</sup>
<b>P 100</b>	<b>PSI</b> (Pressure/psi)	0 to 100	0 to 100	0.5	1	P499RAP-101C P499RAP-101K P499RCP-101C P499RCP-101K P598RAPSN101C P598RAPSN101K P598RCPSN101C P598RCPSN101K
<b>P 110<sup>3</sup></b>	<b>InHg/PSI</b> (Pressure in.Hg/psi)	-10 to 100	-10 to 100	0.5	1	P499RAPS-100C P499RAPS-100K P499RCPS-100C P499RCPS-100K P598RAPSN100C P598RAPSN100K P598RCPSN100C P598RCPSN100K
<b>P 200</b>	<b>PSI</b> (Pressure/psi)	0 to 200	0 to 200	1	1	P499RAP-102C P499RAPS102C P499RAPS102K P499RCPS102C P499RCPS102K P598RAPSN102C P598RAPSN102K P598RCPSN102C P598RCPSN102K
<b>P 500</b>	<b>PSI</b> (Pressure/psi)	0 to 500	90 to 500	1	5	P499RAP-105C P499RAP-105K P499RCP-105C P499RCP-105K P598RAPSN105C P598RAPSN105K P598RCPSN105C P598RCPSN105K
<b>P 750</b>	<b>PSI</b> (Pressure/psi)	0 to 750	150 to 750	2	6	P499RAP-107C P499RAP-107K P499RCP-107C P499RCP-107K P598RAPSN107C P598RAPSN107K P598RCPSN107C P598RCPSN107K
<b>HI°F</b>	<b>°F</b> (Temperature/degrees)	-50 to 360	-40 to 350 <sup>4</sup>	1	1	TE-631x, TE-6000-x, TE-68NT-0N00S
<b>HI°C</b>	<b>°C</b> (Temperature/degrees)	-45.5 to 182	-40 to 176 <sup>4</sup>	0.5	0.5	TE-631x-x TE-6000-x TE-68NT-0N00S
<b>bin</b>	Open or Closed <sup>5</sup> (Dry Contacts)	N/A	N/A	N/A	N/A	N/A







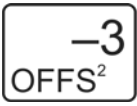

1. See *Differential Control* on page 14 for information on setting up the System 450 Differential Control feature.

2. Refer to the *System 450 Series Modular Controls Product Bulletin (LIT-12011458)*, *Catalog Page (LIT-1900549)*, or the *System 450 Series Controls Systems Technical Bulletin (LIT-12011459)* for additional ordering information for System 450 compatible sensors and transducers.
3. See [Setting Up Outputs That Reference a P110 Sensor](#) on page 12 for information on setting up System 450 outputs that reference the P110 Sensor Type.
4. Many of the temperature sensors that can be set up as HI°F or HI°C Sensor Types are not designed for use across the entire range of usable values for HI°F and HI°C Sensor Types. Refer to the Technical Specifications for the sensor you intend to use to determine the ambient temperature range that the sensor is specified to operate in. The TE-6000-6 Nickel Sensor is the only sensor designed for use over the entire temperature range.
5. Selecting the **bin** Sensor Type for a sensor (Sn-1, Sn-2, or Sn-3) sets up the input to control relay outputs (only) based on the state of the binary input contacts (open or closed) connected to the sensor input (Sn1, Sn2, or Sn3). See [Binary Input Control for Relay Outputs](#) on page 13 for more information. Can only be used for relay outputs.

**Table 5: System 450 Sensor Setup Screen Information and Procedures (Part 1 of 2)**

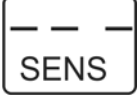
LCD Screen	Name, Description/Function, User Action, and Example
	<p><b>Sensor Setup Start Screen:</b> The Sensor Setup Start screen is the first screen that is displayed when you access the System 450 setup screens. From the Sensor Setup Start screen, you can navigate to the Output Setup Start screens or the Sensor Setup screens. See Figure 6.</p> <p><b>Note:</b> You must set up the input sensors before you can set up the control system outputs. The Sensor Setup Start screen is view-only; selections are not made in Setup Start screens.</p> <p><b>1. In the Sensor Setup Start screen, press  to go to the first Sensor Type Selection screen (Sn-1) and begin setting up the sensors in your control system.</b></p> <p>The screen example shows the <b>Sensors</b> Setup Start screen with flashing dashes.</p>
	<p><b>Sensor Type Selection Screens:</b> The Sensor Type that you select for an input sensor automatically determines the setup parameters and values for each output that is set up to reference that sensor. See Table 4 for information about System 450 sensors/transducers, Sensor Types, condition type, units of measurement, minimum control band or proportional band, setup values, value ranges, and product code numbers.</p> <p><b>Note:</b> For outputs to operate properly, the selected Sensor Type must match the sensor/transducer model wired to the control module, and the sensor/transducer must be wired to the proper control module input terminals.</p> <p><b>2. In the Sn-1 Sensor Type Selection screen, press  or  to select a Sensor Type. Press  to save your selection and go to the Sn-2 Sensor Type Selection screen.</b></p> <p><b>3. In the Sn-2 Sensor Type Selection screen, press  or  to select a Sensor Type. Press  to save your selection and go to the Sn-3 Sensor Type Selection screen.</b></p> <p><b>Note:</b> If your control system does not use three input sensors, simply press  while the two dashes are flashing in a Sensor Type Selection screen to save <b>no Sn-3</b> Sensor Type and go to the next setup screen.</p> <p><b>4. In the Sn-3 Sensor Type Selection screen, press  or  to select a Sensor Type. Press  to save your selection and either:</b></p> <ul style="list-style-type: none"> <li>• go to the <b>Temperature Offset Setup</b> screen for the first temperature sensor in your system.</li> <li>• return to the <b>Sensor Setup Start Screen</b>, if your control system has no temperature sensors.</li> </ul> <p><b>Note:</b> Beginning with firmware Version 2.00, if you select the same Sensor Type for Sn-1 and Sn-2, two additional functional sensors (Sn-d and HI-2) are available for selection when you set up the control system outputs. If you select the same Sensor Type for Sn-1, Sn-2, and Sn-3, then functional sensor HI-3 is also available for selection when you set up outputs. See <u><a href="#">High Input-Signal Selection</a></u> on page 13 and <u><a href="#">Differential Control</a></u> on page 14 for more information.</p> <p>The screen examples show <b>Sn-1</b> with the <b>P500</b> Sensor Type selected, <b>Sn-2</b> with the <b>°F</b> Sensor Type selected, and <b>Sn-3</b> with the <b>no</b> Sensor Type selected.</p>

**Table 5: System 450 Sensor Setup Screen Information and Procedures (Part 2 of 2)**

LCD Screen	Name, Description/Function, User Action, and Example
	<p><b>Temperature Offset Selection Screens:</b> Select a temperature offset for the temperature inputs (only) in your control system.</p> <p>Sensor Type °F enables an offset of +/- 5°F in 1 degree increments.            Sensor Type °C enables an offset of +/- 2.5°C in 0.5 degree increments.</p> <p><b>Note:</b> The temperature offset changes the displayed temperature value by the selected offset value.</p> <p><b>5. Press  or  to select a temperature offset value. Press  to save your selection and either:</b></p> <ul style="list-style-type: none"> <li>• go to the next Temperature Offset Selection screen (if there are additional temperature sensors in your control system) and repeat this step for each temperature sensor.</li> <li>• return to the Sensor Setup Start screen.</li> </ul> <p>The screen example shows an <b>OFFS</b> value of -3 (°F) for Sensor 2. Therefore a sensed temperature value of 75 (°F) at Sensor 2 is displayed as 72 (°F).</p>
	<p><b>Sensor Setup Start Screen:</b> When you have finished setting up all of the sensors for your control system, the display returns to the Sensor Setup Start screen.</p> <p><b>Note:</b> You can edit the sensor setup values at any time, if required. However, changing the Sensor Type for a sensor that is referenced by an output requires setting up the output again to the new Sensor Type values.</p> <p><b>After the sensors are set up for your control system, you can:</b></p> <ul style="list-style-type: none"> <li>• press  to scroll through the Output Setup Start screens and begin setting up your system outputs.</li> <li>• press  and  simultaneously to return to the Main screens.</li> </ul> <p>The screen example shows <b>Sensors</b> Setup Start screen with flashing dashes.</p>

**Setting Up Outputs That Reference a P110 Sensor**

The P110 Sensor Type can monitor negative pressure down to 20 InHg (-10 psi). When referencing a P110 sensor, System 450 displays negative pressure values in InHg on the Main and System Status screens.

But when you set up an output that references a P110 sensor and the setup value is a negative pressure value, you must select a pressure value in negative psi.

Use Table 6 to determine the negative psi setup value that corresponds to your InHg target value. For example, if you want a relay output to go off when the sensed pressure reaches 7 InHg, you select the value -3.5 (psi) in the output's Relay OFF Selection screen.

**Table 6: InHg Target Values/PSI Setup Values**

InHg Value	psi Setup Value	InHg Value	psi Setup Value
1	-0.5	11	-5.5
2	-1.0	12	-6.0
3	-1.5	13	-6.5
4	-2.0	14	-7.0
5	-2.5	15	-7.5
6	-3.0	16	-8.0
7	-3.5	17	-8.5
8	-4.0	18	-9.0
9	-4.5	19	-9.5
10	-5.0	20	-10.0

**Note:** When an output references the P110 Sensor Type and the output is set up for Differential Control (Sn-1 and Sn-2 are P110 Sensor Type), the negative pressure values displayed in the differential pressure System Status screen (dIFP) are displayed as negative psi values, not InHg values. See *Differential Control* on page 14 for more information.

## Binary Input Control for Relay Outputs

You can connect a binary input (dry contacts) to any of the three System 450 control module inputs (Sn1, Sn2, or Sn3) and control the output relays in your control system based on the binary input's state (open or closed).

An input (Sn-1, Sn-2, or Sn-3) that is set up as a binary input can only be referenced by a relay output. Inputs set up as binary inputs are not available for selection on analog outputs.

When a relay output references a sensor that is set up as a binary input, the **On** and **OFF** parameter screens are not available as you set up the output. The relay output's On/Off state is controlled by the binary input's Closed/Open state, respectively, **and** any of the timer parameters (ONT, OFFT, ONd, or OFFd) that you set up for the relay output. Refer to the Binary Input Control for Relay Outputs section of the *System 450™ Series Modular Control Systems with Standard Control Modules Technical Bulletin (LIT-12011459)* for more information.

## High Input-Signal Selection

The High Input-Signal Selection feature enables a System 450 control system to monitor a condition (temperature, pressure, or humidity) with two or three sensors (of the same type) and control relay, analog, or both outputs based on the highest condition value sensed by the two or three referenced sensors.

In two sensor applications (HI-2), Sn-1 and Sn-2 must be the same Sensor Type. In three sensor applications (HI-3), Sn-1, Sn-2, and Sn-3 must be the same Sensor Type.

A System 450 control system that uses High Input-Signal Selection can monitor the outlet pressures of two condenser coils in a multi-circuit condensing unit using two pressure sensors of the same type—one connected to each coil outlet.

If the multi-circuit condensing unit has single-speed fan motors, multiple relay outputs can be set up to reference the high input-signal and System 450 can stage the fans on and off, based on the pressure sensed at the coil with the highest pressure.

If the multi-circuit condensing unit has variable speed fan motors, one or more analog outputs can be set up to reference the high input-signal and control the fan motor speeds based on the pressure sensed at the coil with the highest pressure.

## Differential Control

System 450 control modules include a Differential Control feature. Differential control is used to monitor and maintain a given difference in a condition (temperature, pressure, or humidity) between two sensor points within a system, process, or space.

The Differential Control feature enables a System 450 control system to monitor the temperature, pressure, or humidity differential between two sensors of the same type (Sn-1 and Sn-2) and control relay or analog outputs based on the sensed differential value relative to user-selected differential values (dON, dOFF, dSP, and dEP).

When a Differential Control sensor (Sn-d) is set up, the displayed differential sensor value is a calculated variable value:  $(Sn-d) = (Sn-1) - (Sn-2)$ .

The Sn-d value appears in the System Status screens as either a temperature differential value (dIFT), pressure differential value (dIFP), or humidity differential value (dIFH). The unit of measurement associated with the displayed differential value is determined by the Sn-1 and Sn-2 Sensor Type. See Table 4 on page 9 for Sensor Types and their units of measurement.

The relay output setup values dON and dOFF are condition differential values. When a relay output is set up for differential control, System 450 controls the relay state (On or Off) based on the difference between Sn-1 and Sn-2 (Sn-d) relative to the user-selected differential On (dON) and differential Off (dOFF) values.

When an analog output is set up for differential control, System 450 controls the analog signal strength based on the difference between Sn-1 and Sn-2 (Sn-d) relative to the user-selected differential setpoint (dSP) and differential endpoint (dEP) values.

### Differential Sensor Range of Usable Values

The System 450 Differential Control sensor (Sn-d) value is always equal to Sn-1 minus Sn-2. Depending on the intended control action of the output, the differential value may be either a positive or negative value. Therefore, the range of usable values is twice as large as a single sensor, and each Sensor Type has an equal number of positive and negative values. See Table 7 for the range of usable values when an output references Sn-d.

**Note:** Binary Inputs cannot be set up as a Differential Sensor.

**Table 7: Ranges of Usable Values for Sensor Types in Differential Control Applications**



Sensor Type	Sn-d Range of Usable Values	Sensor Type	Sn-d Range of Usable Values
°F	-290 to 290	P 30	-30.0 to 30.0
°C	-161.0 to 161.0	P 50	-50.0 to 50.0
rH	-95 to 95	P 100	-100.0 to 100.0
P0.25	-0.500 to 0.500	P 110	-110.0 to 110.0
P 0.5	-0.500 to 0.500	P 200	-200 to 200
P 2.5	-2.50 to 2.50	P 500	-500 to 500
P 5	-5.00 to 5.00	P 750	-750 to 750
P 8	-9.00 to 9.00	HI°F	-380 to 380
P 10	-10.00 to 10.00	HI°C	-210.0 to 210.0
P 15	-16.0 to 16.0	--	--

## Setting Up System 450 Outputs

After you build and connect power to your control system module assembly, the output numbers and output types for your control system are automatically assigned in the UI.

**Note:** You must set up the input sensors for your control system before you can set up the outputs. See [Setting Up System 450 Sensors](#) on page 9 for more information.

To set up System 450 outputs in the UI:



1. Apply power to your module assembly. After the **Startup** screen appears briefly (displaying the control module firmware version), the **Main** screen appears on the LCD.
2. In the **Main** screen, press any key to exit idle mode, then press and hold  and  simultaneously for 5 seconds to access the setup screens and to go to the **Sensor Setup Start** screen.
3. At the **Sensor Setup Start** screen, press  repeatedly to scroll through and select the desired **Output Setup Start** screen. The Output Setup Start screen indicates the output number and the output type for the selected output.
4. To set up relay outputs, see [Setting Up a Relay Output](#) and Table 8 for setup information and procedures.
5. To set up analog outputs, see [Setting Up an Analog Output](#) and Table 10 for setup information and procedures.
6. To set up the backlight brightness, see [Setting Up the LCD Backlight Brightness](#) and Table 11 for setup information and procedures.

### Setting Up a Relay Output





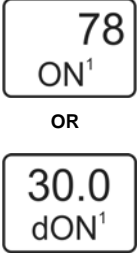





Table 8 provides information, procedures, guidelines, and screen examples for setting up relay outputs on System 450 control modules. See Figure 6 on page 26 for example menu flow of the Relay Output 1 setup in Table 8.

**Note:** The differential sensor, Sn-d, is used to set up analog and relay outputs for Differential Control. See [Differential Control](#) on page 14 for more information.

**Table 8: System 450 Setup Screen Information and Procedures for Relay Outputs (Part 1 of 4)**













LCD Screen	Name, Description/Function, User Action, and Example
	<p><b>Relay Output Setup Start Screen:</b> The output numbers and the output type (relay or analog) are determined by the module types and configuration of your control system's module assembly and are automatically assigned when you connect power to the module assembly. (See <a href="#">Setting Up a Control System in the User Interface</a> on page 5.)</p> <p><b>Note:</b> You must set up the control system input sensors before you can set up the outputs.</p> <p><b>1. In the Relay Output Setup Start screen, press  to go to the output's Sensor Selection screen.</b> The screen example shows a <b>Relay Output Setup Start</b> screen for <b>Output 1</b>.</p>

**Table 8: System 450 Setup Screen Information and Procedures for Relay Outputs (Part 2 of 4)**

LCD Screen	Name, Description/Function, User Action, and Example
	<p><b>Sensor Selection Screen:</b> The sensor you select here determines the output's setup parameters and values, including condition type, unit of measurement, minimum control band, default setup values, and setup value ranges for several of the remaining output setup screens. If a sensor is not selected, the remaining output setup screens do not appear. If a sensor is already selected for this output, the Sensor Selection screen does not appear here and the Relay ON Selection (ON or dON) screen appears instead.</p> <p><b>Notes:</b></p> <ul style="list-style-type: none"> <li>You must select a sensor in this Sensor Selection screen <b>and</b> the selected sensor must be already set up in the System 450 UI. (See <i>Setting Up System 450 Sensors</i>.)</li> <li>On System 450 control modules, the functional sensors Sn-d and HI-2 are available, if Sn-1 and Sn-2 are the same Sensor Type. If Sn-1, Sn-2, and Sn-3 are the same Sensor Type, the functional sensor HI-3 is also available.</li> </ul> <p><b>2. Press  or  to select the sensor that this output references:</b></p> <ul style="list-style-type: none"> <li>For standard control action, select Sn-1, Sn-2, or Sn-3.</li> <li>For standard control action with High Input-Signal Selection, select HI-2 or HI-3.</li> <li>For differential control action, select Sn-d.</li> <li>For binary input control of Relay Outputs, select bin.</li> </ul> <p>Then, press  to save your sensor selection and go to the Standard Relay ON Selection screen or the Relay dON Selection screen.</p> <p>The top screen example shows the initial <b>Sensor</b> Selection screen for Relay Output 1 before a sensor is selected. The remaining screen examples show some of the sensors that may be available for selection. For the Output Relay example, <b>Sn-2</b> is selected as the <b>Sensor</b> for Output 1 as shown in the second screen.</p>
	<p><b>When a relay output references Sn-1, Sn-2, Sn-3, HI-2, or HI-3, the Standard Relay ON Selection screen appears.</b></p> <p><b>Standard Relay ON Selection Screen:</b> Select the value at which the relay turns on. Relay <b>ON</b> is defined as relay LED On (lit), relay contacts N.O. to C are closed, and N.C. to C contacts are open.</p> <p><b>Note:</b> The value ranges and minimum control band are determined by the Sensor Type selected for the sensor that the output references and are enforced in the Relay ON and Relay OFF Selection screens.</p> <p><b>3. Press  or  to select the value at which the output relay turns on, then press  to save your selection and go to Relay OFF Selection screen.</b></p> <p>The screen example shows an <b>ON</b> value of <b>78</b> (°F) selected for Relay Output 1.</p> <p><b>When a relay output references Sn-d, the Differential Relay dON Selection screen appears.</b></p> <p><b>Differential Relay dON Selection Screen:</b> Select the dON value at which the relay turns on. The dON value is a differential value that represents the intended difference in the condition (temperature, pressure, or humidity) between Sn-1 and Sn-2 (Sn-1 minus Sn-2) at which the relay is turned on. Depending on the intended control action and the physical location of Sn-1 and Sn-2 sensors in the condition process, dON may be a positive or negative value.</p> <p><b>Note:</b> The unit of measurement, resolution increment, minimum control band, and range of usable values for dON and dOFF are determined by the Sensor Type selected for Sn-1 and Sn-2. (See Table 4 and Table 7 for more information.)</p> <p><b>3. Press  or  to select the differential value at which the output relay turns on. Press  to save your selection and go to Relay dOFF Selection Screen.</b></p> <p>The screen example shows a <b>dON</b> value of <b>30</b> (psi) selected for Relay Output 1.</p> <p><b>When a relay output references a hard-wired sensor (Sn-1, Sn-2, or Sn-3) that is set up with the bin (binary input) Sensor Type, the ON and OFF screens are not available. If you select and save a sensor set up as a binary input in Step 2, the ON Delay (ONd) screen appears. Go to Step 5.</b></p> <p><b>Binary Input Control:</b> Relay outputs that reference sensors set up with the <b>bin</b> Sensor Type are controlled by the binary input contacts state (open or closed). The ON and OFF values are not used to control relay outputs that reference a binary input sensor.</p>



**Table 8: System 450 Setup Screen Information and Procedures for Relay Outputs (Part 3 of 4)**

LCD Screen	Name, Description/Function, User Action, and Example
<div style="border: 1px solid black; padding: 5px; width: fit-content; margin-bottom: 5px;">75 OFF<sup>1</sup></div> <p style="text-align: center;">OR</p> <div style="border: 1px solid black; padding: 5px; width: fit-content;">32.0 dOFF<sup>1</sup></div>	<p><i>When a relay output references Sn-1, Sn-2, Sn-3, HI-2, or HI-3, the Standard Relay OFF Selection screen appears.</i></p> <p><b>Standard Relay OFF Selection Screen:</b> Select the value at which the relay turns off. Relay <b>OFF</b> is defined as relay LED Off, relay contacts N.C. to C are closed, and N.O. to C contacts are open.</p> <p><b>Note:</b> The value ranges and minimum control band are determined by the Sensor Type selected for the sensor that the output references and are enforced in the Relay ON and Relay OFF Selection screens.</p> <p><b>4. Press  or  to select the value at which output relay turns off, then press  to save your selection and go to Relay-ON Delay Time Selection screen.</b></p> <p>The screen example shows an <b>OFF</b> value of <b>75</b> (°F) selected for Relay Output 1.</p> <hr/> <p><i>When a relay output references Sn-d, the Differential Relay dOFF Selection screen appears.</i></p> <p><b>Differential Relay dOFF Selection Screen:</b> Select the dOFF value at which the relay turns on. The dOFF value is a differential value that represents the intended difference in the condition (temperature, pressure, or humidity) between Sn-1 and Sn-2 (Sn-1 minus Sn-2) at which the relay is turned off. Depending on the intended control action and the physical location of Sn-1 and Sn-2 sensors in the condition process, dOFF may be a positive or negative value. <b>dOFF</b> is defined as relay LED Off, relay contacts N.C. to C are closed, and N.O. to C contacts are open.</p> <p><b>Note:</b> The unit of measurement, resolution increment, minimum control band, and range of usable values for dON and dOFF are determined by the Sensor Type selected for Sn-1 and Sn-2. (See Table 4 and Table 7 for more information.)</p> <p><b>4. Press  or  to select the differential value at which output relay turns off. Press  to save your selection and go to the Relay-ON Delay Time Selection Screen.</b></p> <p>The screen example shows a <b>dOFF</b> value of <b>32</b> (psi) selected for Relay Output 1.</p> <hr/> <p><i>When a Relay Output references a hard-wired sensor (Sn-1, Sn-2, or Sn-3) that is set up with the bin (binary input) Sensor Type, the ON and OFF screens are not available. If you select and save a sensor set up as a binary input in Step 2, the ON Delay (ONd) screen appears. Go to Step 5.</i></p> <p><b>Binary Input Control:</b> Relay outputs that reference a sensor set up with the <b>bin</b> Sensor Type are controlled by the binary input contacts state (open or closed). The ON and OFF values are not used to control relay outputs that reference a binary input sensor.</p>
<div style="border: 1px solid black; padding: 5px; width: fit-content;">30 ONd<sup>1</sup></div>	<p><b>Relay-On Delay Time Selection Screen:</b> Select the value (in seconds) that you want output relay to delay turning ON after the condition reaches and maintains the Relay-On value. The Relay-On Delay time range is 0 to 300 seconds.</p> <p><b>Note:</b> Beginning with firmware Version 4.00, the Relay-On Delay feature can be used to delay the output relay from going to the On state after the On value is reached at the referenced input sensor. The condition change must reach or exceed the output's Relay-On value for the entire duration of the Relay-On Delay, before the output relay goes On. This feature can be used to prevent controlled equipment such as actuators from being exercised every time the condition momentarily spikes to the Relay-On value, reducing wear on the controlled equipment.</p> <p><b>5. Press  or  to select the time value (in seconds) that the output relay delays turning on after the process condition reaches the Relay-On value, then press  to save your selection and go to the Relay-On Delay Time Selection Screen.</b></p> <p>The screen example shows an <b>ONd</b> value of <b>30</b> (seconds) selected for Output 1.</p>
<div style="border: 1px solid black; padding: 5px; width: fit-content;">0 OFFd<sup>1</sup></div>	<p><b>Relay-Off Delay Time Selection Screen:</b> Select the value (in seconds) that you want output relay to delay turning Off after the condition reaches and maintains the Relay-Off value. The Relay-Off Delay time range is 0 to 300 seconds.</p> <p><b>Note:</b> Beginning with firmware Version 4.00, the Relay-Off Delay feature can be used to delay the output relay from going to the Off state after the Off value is reached at the referenced input sensor. The condition change must reach or exceed the output's Relay-Off value for the entire duration of the Relay-Off Delay, before the output relay goes Off. This feature is used to prevent controlled equipment such as actuators from being exercised every time the condition momentarily spikes to the Relay-Off value, reducing wear on the controlled equipment.</p> <p><b>6. Press  or  to select the time value (in seconds) that the output relay delays turning off after the process condition reaches the Relay-Off value, then press  to save your selection and go to the Relay-Off Delay Time Selection Screen.</b></p> <p>The screen example shows an <b>OFFd</b> value of <b>0</b> (seconds) selected for Output 1.</p>

**Table 8: System 450 Setup Screen Information and Procedures for Relay Outputs (Part 4 of 4)**

LCD Screen	Name, Description/Function, User Action, and Example
	<p><b>Minimum Relay ON Time Selection Screen:</b> Select the minimum time that the output relay is required to stay on after it turns on. The minimum ON Time range is <b>0</b> to <b>300</b> seconds.</p> <p><b>7. Press  or  to select the minimum time that the output relay remains on after reaching the Relay ON value, then press  to save your selection and go to the Minimum Relay OFF Time Selection screen.</b></p> <p>The screen example shows an <b>ONT</b> value of <b>0</b> (seconds) selected for Output 1.</p>
	<p><b>Minimum Relay OFF Time Selection Screen:</b> Select the minimum time that the output relay is required to stay Off after it turns Off. Minimum OFF Time range is <b>0</b> to <b>300</b> seconds.</p> <p><b>8. Press  or  to select the minimum time that this output relay remains off after reaching the Relay OFF value. Press  to save your selection and go to the Sensor Failure Mode Selection screen.</b></p> <p>The screen example shows an <b>OFFT</b> value of <b>120</b> (seconds) selected for Output 1.</p>
	<p><b>Sensor Failure Mode Selection Screen:</b> Select the output's mode of operation if a referenced sensor or sensor wiring fails. For outputs that reference functional sensors HI-2, HI-3, or Sn-d, the failure of any of the referenced hard-wired sensors results in a functional sensor failure condition. The output operates in the selected Sensor Failure mode until the failure is remedied. Sensor Failure mode selections for relay outputs include:</p> <ul style="list-style-type: none"> <li>• <b>ON</b> = Output relay remains on during sensor failure.</li> <li>• <b>OFF</b> = Output relay remains off during sensor failure.</li> </ul> <p><b>9. Press  or  to select this output's mode of operation if the sensor or sensor wiring fails. Press  to save your sensor failure mode selection and go to the Edit Sensor screen.</b></p> <p>The screen example shows <b>OFF</b> selected as the <b>Sensor Failure</b> mode for Output 1.</p>
	<p><b>Edit Sensor Screen:</b> This screen displays the sensor that this output currently references. Typically, no action is taken in this screen. But if you need to change the sensor that this output references, you can select a different sensor for this output in this screen.</p> <p><b>Note:</b> If you change the sensor that an output references to a sensor with a different Sensor Type, the default setup values for the output change, and you must set the output up again.</p> <p><b>10. If you do not need to change this output's sensor, simply press  to save the current sensor selection and return to the Relay Output Setup Start screen.</b></p> <p><b>To change the sensor this output references, press  or  to select the new sensor that this output references. Then press  to save the new sensor selection and return to the Relay ON Selection screen (ON or dON). If the new sensor has a different Sensor Type from the previously referenced sensor, repeat the output setup procedure for this output.</b></p> <p>This relay output is now set up in the System 450 UI. The screen example shows <b>Sn-2</b> is selected <b>Sensor</b> for Output 1.</p>
	<p><b>Relay Output Setup Start Screen</b></p> <p>After you have set up this relay output, you can go to another Output Setup Start screen, the Sensor Setup Start screen, or return to the Main screens.</p> <p><b>11. Press  to scroll through the remaining Output Setup Start screens and return to the Sensor Setup Start screen, or press  and  simultaneously to return to the System 450 Main screens.</b></p> <p>The screen example shows a <b>Relay Output Setup Start</b> screen for <b>Output 1</b>.</p>

**Setting Up an Analog Output**

Analog outputs provide an analog signal to control equipment in your application based on the input from a standard fixed setpoint sensor (Sn-1, Sn-2, or Sn-3) or a High Input Signal Selection sensor (HI-2 or HI-3).

**Note:** The differential sensor, Sn-d, is used to set up analog and relay outputs for Differential Control. See [Differential Control](#) on page 14 for more information.

Analog outputs provide an auto-selecting analog signal that is proportional to the sensed input condition. The System 450 analog output senses the impedance of the controlled equipment's analog input circuit and automatically delivers either a 0–10 VDC or 4–20 mA signal to the controlled equipment.

Figure 5 shows an example of the analog output setup values and the resulting output signal in a typical space heating application (SP > EP and OSP < OEP).

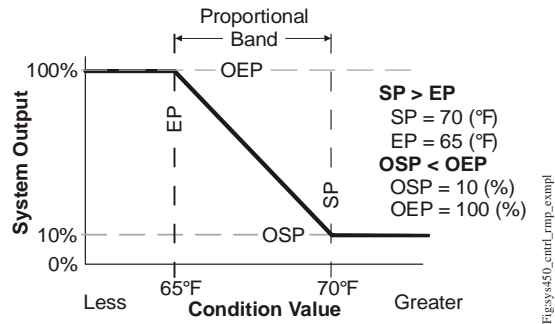
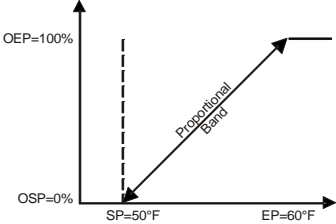

**Figure 5: Control Ramp Example for a Typical Heating Application (SP > EP and OSP < OEP)**



The control action between the input signal and the output signal can be set up four ways, depending on the values selected for the Setpoint (SP), End Point (EP), Percent Output Signal Strength at Setpoint (OSP), and Percent Output Signal Strength at End Point (OEP). The LCD displays different Control Ramp icons for the four control actions.

Table 9 shows the four Control Ramp icons and the associated analog output setup value relationships.

**Table 9: Analog Output Control Ramp Icons**

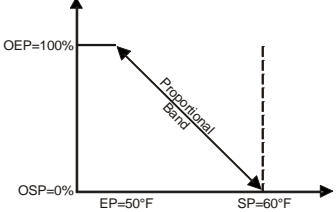
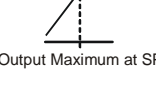
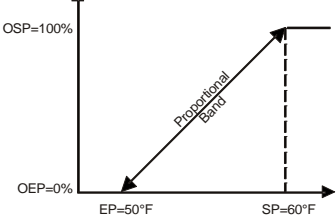
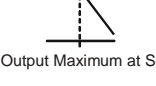
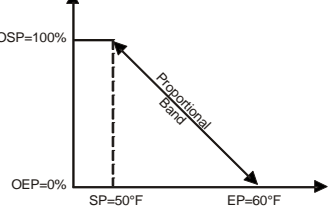
Control Ramp Displayed on LCD	Control Action	Set the Analog Output Value Relationships for the Desired Control Action and Control Ramp
 <p>Output Minimum at SP</p>		<p><b>SP &lt; EP</b></p> <p><b>OSP &lt; OEP</b></p>
 <p>Output Minimum at SP</p>		<p><b>SP &gt; EP</b></p> <p><b>OSP &lt; OEP</b></p>
 <p>Output Maximum at SP</p>		<p><b>SP &gt; EP</b></p> <p><b>OSP &gt; OEP</b></p>
 <p>Output Maximum at SP</p>		<p><b>SP &lt; EP</b></p> <p><b>OSP &gt; OEP</b></p>

## Setting Up the Integration Constant, Update Rate, and Output Deadband

The System 450 Integration Constant (I-C), the Update Output Signal Rate (UP-R), and the Output Signal Strength Deadband (bNd) are powerful tools for controlling the analog outputs and your application's process loops.







Depending on your control system application, setting up the I-C, UP-R, or bNd values to those other than the factory-default values can significantly change the behavior of an analog output. Refer to the *System 450™ Series Modular Control Systems with Standard Control Modules Technical Bulletin (LIT-12011459)* for more information.

**IMPORTANT:** If you set the I-C, UP-R, or bNd values to something other than the default value, you should operate and observe the affected analog outputs and process loops through the entire range of control. Failure to observe and adjust an analog output set up to use the I-C, UP-R, or bNd features can result in unexpected behavior and out of range conditions in the affected process loops.



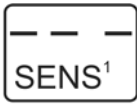
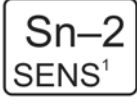
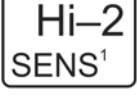
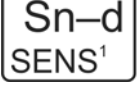











Table 10 provides information, procedures, guidelines, and screen examples for setting up analog outputs on System 450 control modules.

See Figure 6 on page 26 for example menu flow of the Analog Output 3 set up in Table 10.

**Table 10: System 450 Setup Screen Information and Procedures for Analog Output (Part 1 of 4)**















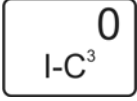

LCD Screen	Name, Description/Function, User Action, and Example
	<p><b>Analog Output Setup Start Screen:</b> The output numbers and the output type (relay or analog) are determined by the module types and configuration of your control system's module assembly and are automatically assigned when you connect power to the module assembly. (See <i>Setting Up a Control System in the User Interface</i> on page 5.)</p> <p><b>Note:</b> You must set up the system's sensors before you can set up the outputs.</p> <p><b>1. Press  to go to this output's Sensor Selection screen.</b></p> <p>The screen example shows the <b>Analog</b> Output Setup Start screen for <b>Output 3</b>.</p>
   	<p><b>Sensor Selection Screen:</b> The selected sensor determines this output's setup parameters and values, including condition type, unit of measurement, minimum proportional band, default setup values, and setup value ranges for several of the remaining output setup screens. If a sensor is not selected here, this output's remaining setup screens do not appear. If a sensor is already selected for this output, the Sensor Selection screen does not appear here, and the Setpoint Selection (SP or dSP) screen appears instead.</p> <p><b>Notes:</b></p> <ul style="list-style-type: none"> <li>You must select a sensor in this Sensor Selection screen <b>and</b> the selected sensor must be already set up in the System 450 UI. (See <i>Setting Up System 450 Sensors</i>.)</li> <li>On System 450 control modules, the functional sensors Sn-d and HI-2 are available if Sn-1 and Sn-2 are the same Sensor Type. If Sn-1, Sn-2, and Sn-3 are the same Sensor Type, the functional sensor HI-3 is also available. The Binary Input sensor is not available for analog outputs.</li> </ul> <p><b>2. Press  or  to select the sensor that this output references:</b></p> <ul style="list-style-type: none"> <li><b>For standard control action, select Sn-1, Sn-2, or Sn-3.</b></li> <li><b>For standard control action with High Input-Signal Selection, select HI-2 or HI-3.</b></li> <li><b>For differential control action, select Sn-d.</b></li> </ul> <p><b>Then press  to save your sensor selection and go to the Setpoint Selection screen.</b></p> <p>The top screen example shows the initial <b>Sensor</b> Selection screen for Analog Output <b>3</b> before a sensor is selected. The remaining screen examples show some of the sensors that may be available for selection. For the analog output example, <b>Sn-1</b> is the selected <b>Sensor</b> for Output <b>3</b> as shown in the second screen.</p>

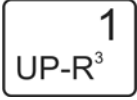
**Table 10: System 450 Setup Screen Information and Procedures for Analog Output (Part 2 of 4)**



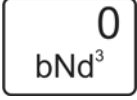









LCD Screen	Name, Description/Function, User Action, and Example
<div style="border: 1px solid black; padding: 5px; width: fit-content; margin-bottom: 5px;">225 SP<sup>3</sup></div> <p style="text-align: center;">OR</p> <div style="border: 1px solid black; padding: 5px; width: fit-content;">30.0 dSP<sup>3</sup></div>	<p><b>When an analog output references Sn-1, Sn-2, Sn-3, HI-2, or HI-3, the Standard Setpoint Selection screen appears.</b></p> <p><b>Setpoint Selection Screen:</b> Setpoint is the target value that the controlled system drives toward and, along with End Point, defines this output's proportional band.</p> <p><b>Note:</b> An output's minimum proportional band (between Setpoint and End Point) is automatically enforced in the output's Setpoint and End Point Selection screens.</p> <p><b>3. Press  or  to select this output's Setpoint value. Press  to save your Setpoint value selection and go to the End Point Selection screen.</b></p> <p>The screen example shows a <b>Setpoint</b> value of <b>225</b> (psi) selected for Output 3.</p> <hr/> <p><b>When an analog output references Sn-d, the Differential Setpoint Selection screen appears.</b></p> <p><b>Differential Setpoint Selection Screen:</b> Differential Setpoint (dSP) is the target value that the controlled system drives toward, and along with Differential End Point (dEP), defines this output's proportional band. The dSP value is a differential value that represents a (selected) difference in the condition (temperature, pressure, or humidity) between Sn-1 and Sn-2 (Sn-1 minus Sn-2). Depending on the intended proportional control action and the physical location of Sn-1 and Sn-2 sensors in the condition process, dSP may be a positive or negative value.</p> <p><b>Note:</b> The unit of measurement, resolution increment, minimum proportional band, and range of usable values for dSP and dEP are determined by the Sensor Type selected for Sn-1 and Sn-2. (See Table 4 and Table 7 for more information.) The output's minimum proportional band (between dSP and dEP) is automatically enforced in the output's Setpoint and End Point Selection screens.</p> <p><b>3. Press  or  to select this output's Differential Setpoint value. Press  to save your Differential Setpoint value selection and go to the End Point Selection screen.</b></p> <p>The screen example shows a <b>dSP</b> value of <b>30</b> (psi) selected for Output 3.</p>
<div style="border: 1px solid black; padding: 5px; width: fit-content; margin-bottom: 5px;">235 EP<sup>3</sup></div> <p style="text-align: center;">OR</p> <div style="border: 1px solid black; padding: 5px; width: fit-content;">25.0 dEP<sup>3</sup></div>	<p><b>When the analog output references Sn-1, Sn-2, Sn-3, HI-2, or HI-3, the Standard End Point Selection screen appears.</b></p> <p><b>End Point Selection Screen:</b> End Point is the value that the controlled system drives away from (toward Setpoint) and, along with Setpoint, defines this output's proportional band.</p> <p><b>Note:</b> An output's minimum proportional band (between Setpoint and End Point) is automatically enforced in the output's Setpoint and End Point Selection screens.</p> <p><b>4. Press  or  to select this output's End Point value. Press  to save your End Point value selection and go to the %Output Signal Strength at Setpoint Selection screen.</b></p> <p>The screen example shows an <b>End Point</b> value of <b>235</b> (psi) selected for Output 3.</p> <hr/> <p><b>When the analog output references Sn-d, the Differential End Point Selection screen appears.</b></p> <p><b>Differential End Point Selection Screen:</b> Differential End Point (dEP) is the target value that the controlled system drives away from (toward Differential Setpoint) and along with Differential Setpoint (dSP), defines this output's proportional band. The dEP value is a differential value that represents a (selected) difference in the condition (temperature, pressure, or humidity) between Sn-1 and Sn-2 (Sn-1 minus Sn-2). Depending on the intended proportional control action and the physical location of Sn-1 and Sn-2 sensors in the condition process, dEP may be a positive or negative value.</p> <p><b>Note:</b> The unit of measurement, resolution increment, minimum proportional band, and range of usable values for dSP and dEP are determined by the Sensor Type selected for Sn-1 and Sn-2. (See Table 4 and Table 7 for more information.) The output's minimum proportional band (between dSP and dEP) is automatically enforced in the output's Setpoint and End Point Selection screens.</p> <p><b>4. Press  or  to select this output's Differential End Point value. Press  to save your Differential End Point value selection and go to the %Output Signal Strength at Setpoint Selection screen.</b></p> <p>The screen example shows a <b>dEP</b> value of <b>25</b> (psi) selected for Output 3.</p>
<div style="border: 1px solid black; padding: 5px; width: fit-content;">10 OSP<sup>3</sup></div>	<p><b>Output Signal Strength at Setpoint Selection Screen:</b> Select the strength of the signal that this output generates when the sensed condition is at the Setpoint value. The signal strength range is <b>0</b> to <b>100</b> (%).</p> <p><b>5. Press  or  to select this output's %Output Signal Strength at Setpoint (OSP) value. Press  to save your selection and go to the %Output Signal Strength at End Point Selection screen.</b></p> <p>The screen example shows an <b>OSP</b> value of <b>10</b> (%) selected for Output 3. Therefore, Output 3 generates 10% of the total signal strength (1 V or 5.6 mA) when the input is at the Setpoint value of 200 (psi).</p>

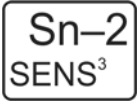

**Table 10: System 450 Setup Screen Information and Procedures for Analog Output (Part 3 of 4)**

LCD Screen	Name, Description/Function, User Action, and Example
	<p><b>Output Signal Strength at End Point Selection Screen:</b> Select the strength of the signal that this output generates when the sensed condition is at the End Point value. The signal strength range is <b>0</b> to <b>100</b> (%).</p> <p><b>6. Press  or  to select this output's %Output Signal Strength at End Point value. Press  to save your selection and go to the Integration Constant Selection screen.</b></p> <p>The screen example shows an <b>OEP</b> value of <b>90</b> (%) selected for Output <b>3</b>. Therefore Output 3 generates 90% of the total signal strength (9 V or 18.4 mA) when the input is at the End Point value of 250 (psi).</p>
	<p><b>Integration Constant Selection Screen:</b> An integration constant allows you to set up proportional plus integral control for this analog output. Proportional plus integral control can drive the load closer to Setpoint than proportional only control.</p> <p><b>Note:</b> Initially, you should select the I-C value of <b>0</b> (zero) for no integration constant. Refer to the <i>System 450 Series Technical Bulletin (LIT-12011459)</i> for more information on proportional plus integral control and setting an integration constant in the System 450 UI.</p> <p><b>7. Press  or  to select this output's Integration Constant for proportional plus integral control. Press  to save your selection and go to the Output Update Rate Selection screen.</b></p> <p>The screen example shows an <b>I-C</b> value of <b>0</b> (zero) selected for Output <b>3</b>.</p>
	<p><b>Output Signal Update Rate Selection Screen:</b> Select the time interval in seconds at which the output updates the output signal strength. The selected Output Signal Update Rate is the minimum time that the output maintains a constant signal strength (regardless of the input signal) before updating the output signal in response to the referenced input signal. The Output Signal Update Rate value range is 1 to 240 (seconds).</p> <p><b>Note:</b> Beginning with firmware Version 4.00, the Output Update Rate is used to reduce excessive cycling or repositioning of controlled equipment, such as valve and damper actuators. The Output Signal Update Rate feature can be used in conjunction with the Output Signal Deadband feature.</p> <p><b>8. Press  or  to select this output's Output Signal Update Rate. Press  to save your selection and go to the Output Signal Deadband Selection screen.</b></p> <p>The screen example shows an Output Update Rate value of 1 (second), which is the default and lowest update rate you can select.</p>
	<p><b>Output Signal Deadband Selection Screen:</b> Select the Output Signal Deadband value (as a percent of the output signal strength range) to establish a deadband around the analog output signal strength. The analog output responds to a changing input signal and updates the output signal strength whenever the input signal moves outside of the selected Output Signal Deadband.</p> <p>At each update of the output signal, the control determines if the calculated (input-induced) output signal strength is within the selected Output Signal Deadband or not. If the input-induced change of the output signal strength is within the selected Output Signal Deadband, the output signal strength is not updated and remains unchanged. If the input-induced change of the output signal falls outside the Output Signal Deadband, the output signal strength is updated to the new signal strength value and the selected Output Signal Deadband is applied to the new signal strength value. The Output Signal Deadband range is 0 to 50% of the OSP to OEP range.</p> <p><b>Note:</b> Beginning with firmware Version 4.00, the Output Signal Deadband is used to reduce excessive cycling or repositioning of controlled equipment, such as valve and damper actuators. The Output Signal Deadband feature can be used in conjunction with the Output Signal Update Rate feature.</p> <p><b>9. Press  or  to select this output's Output Signal Deadband. Press  to save your selection and go to the Sensor Failure Mode Selection screen.</b></p> <p>The screen example shows an Output Deadband value of 0 (%), which is the default value and disables the Output Deadband feature.</p>

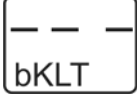









**Table 10: System 450 Setup Screen Information and Procedures for Analog Output (Part 4 of 4)**

LCD Screen	Name, Description/Function, User Action, and Example
	<p><b>Sensor Failure Mode Selection Screen:</b> Select the output's mode of operation if a referenced sensor or sensor wiring fails. For outputs that reference functional sensors HI-2, HI-3, or Sn-d, the failure of any of the referenced hard-wired sensors results in a functional sensor failure condition. The output operates in the selected Sensor Failure mode until the failure is remedied. Sensor Failure mode selections for analog outputs include:</p> <ul style="list-style-type: none"> <li>• <b>ON</b> = Output generates the selected OEP signal strength during sensor failure.</li> <li>• <b>OFF</b> = Output generates the selected OSP signal strength during sensor failure.</li> </ul> <p><b>10. Press  or  to select this output's mode of operation if the sensor or sensor wiring fails. Press  to save your selection and go to the Edit Sensor Selection screen.</b></p> <p>The screen example shows <b>OFF</b> selected as the <b>Sensor Failure</b> mode for Output 3.</p>
	<p><b>Edit Sensor Selection Screen:</b> This screen displays the sensor that this output currently references. Typically, no action is taken in this screen. But if you need to change the sensor that this output references, you can select a different sensor for this output in this screen.</p> <p><b>Note:</b> If you change the sensor that an output references to a sensor with a different Sensor Type, the default setup values for the output change, and you must set the output up again.</p> <p><b>11. If you are not changing this output's sensor, simply press  to save the current sensor selection and return to the Analog Output Setup Start screen.</b></p> <p><b>To change the sensor this output references, press  or  to select the new sensor that this output references. Then press  to save the new sensor selection and return to the Setpoint Selection screen (SP or dSP). If the new sensor has a different Sensor Type from the previously referenced sensor, repeat the output setup procedure for this output.</b></p> <p>The screen example shows <b>Sn-2</b> as the selected Sensor for Output 3.</p>
	<p><b>Analog Output Setup Start Screen:</b> After you have set up this analog output, you can go to another Output Setup Start screen, the Sensor Setup Start screen, or return to the Main screens.</p> <p><b>12. Press  to scroll through the remaining Output Setup Start screens and return to the Sensor Setup Start screen, or press  and  simultaneously to return to the System 450 Main screens.</b></p> <p>The screen example shows the Analog Output Setup Start screen for Output 3.</p>

**Setting Up the LCD Backlight Brightness**

Beginning with firmware Version 4.00, the LCD backlight brightness can be adjusted in the UI. Table 11 provides information, procedures, guidelines, and screen examples for setting up the backlight brightness on System 450 control modules. See Figure 6 on page 26 for an example menu flow of the backlight set up in Table 11.

**Table 11: System 450 Setup Screen Information and Procedures for Backlight Brightness (Part 1 of 2)**

LCD Screen	Name, Description/Function, User Action, and Example
	<p><b>Backlight Setup Start Screen:</b> The Backlight Brightness level feature allows you to adjust the LCD backlight intensity. The selected backlight low level value is applied when the control is in idle mode. When you enter the programming menus to set up the control or press any key, the LCD automatically goes to the selected backlight high level value.</p> <p><b>1. Press  to go to the Edit Backlight Low Level screen.</b></p> <p>The screen example shows the Backlight Setup Start screen.</p>
	<p><b>Backlight Low Level:</b> The backlight low level defines the brightness of the backlight during regular or idle mode, when you are not making adjustments to the control.</p> <p><b>2. Press  or  to select the backlight brightness low level value. Press  to save your selection and go to the Edit Backlight High Level screen.</b></p> <p>The screen example shows the Backlight low level set to OFF.</p>
	<p><b>Backlight High Level:</b> The high level defines the brightness when you are making configuration changes to the control and interacting with the UI. The backlight high level can be set to values 1–10; it cannot be turned completely off.</p> <p><b>3. Press  or  to select the backlight brightness high level value. Press  to save your selection and return to the Backlight Setup Start screen.</b></p> <p>The screen example shows the Backlight high level set to 10.</p>



**Table 11: System 450 Setup Screen Information and Procedures for Backlight Brightness (Part 2 of 2)**





LCD Screen	Name, Description/Function, User Action, and Example
	<p><b>Backlight Setup Start Screen</b></p> <p>After you have set up the backlight brightness level, you can go to the Sensor Setup Start screen, or return to the Main screens.</p> <p><b>4. Press  to return to the Sensor Setup Start screen, or press  and  simultaneously to return to the System 450 Main screens.</b></p> <p>The screen example shows the Backlight Setup Start screen.</p>

Figure 6: System 450 Status Screens, Setup Screens, and Menu Flow Example

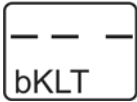
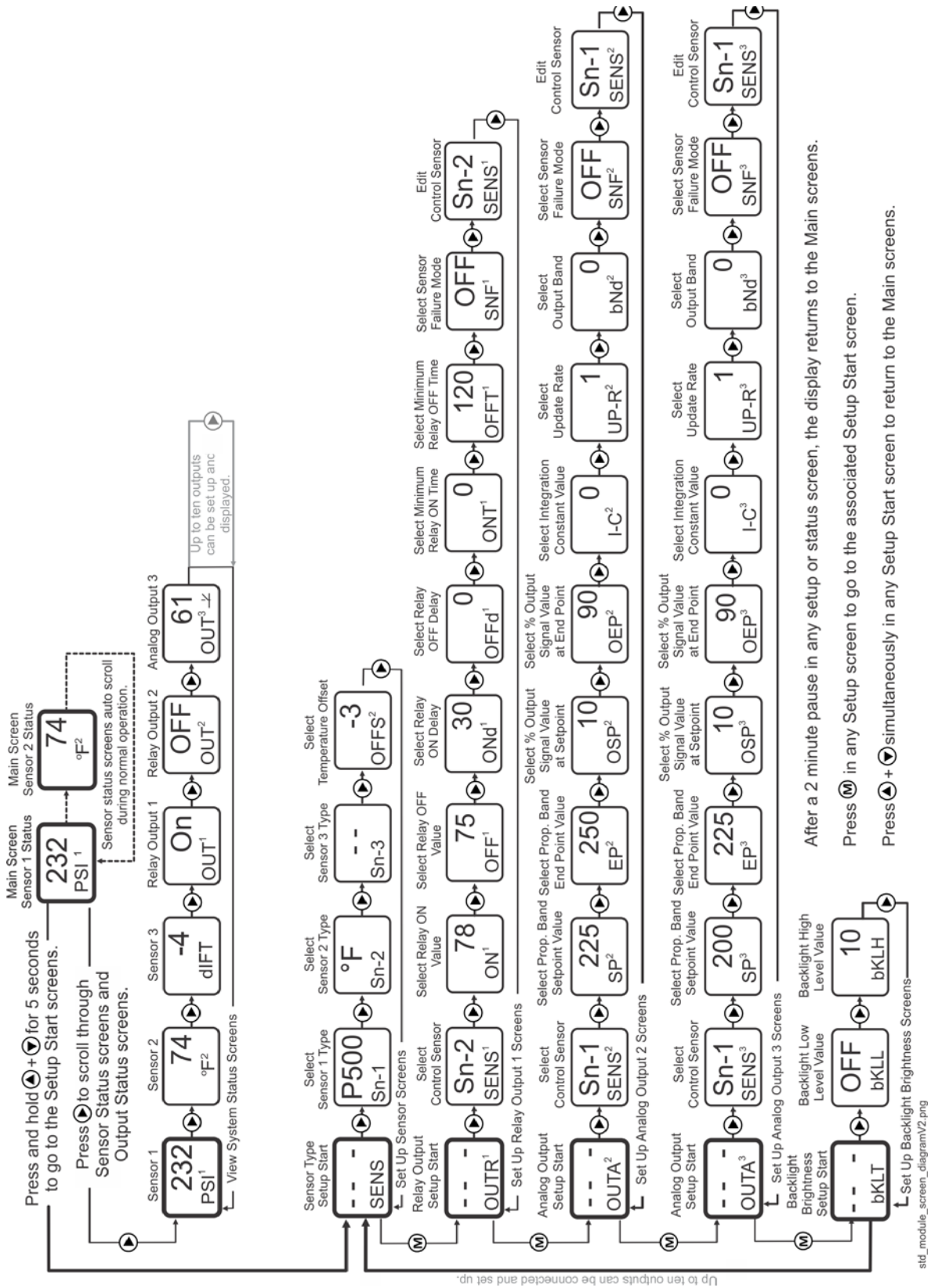
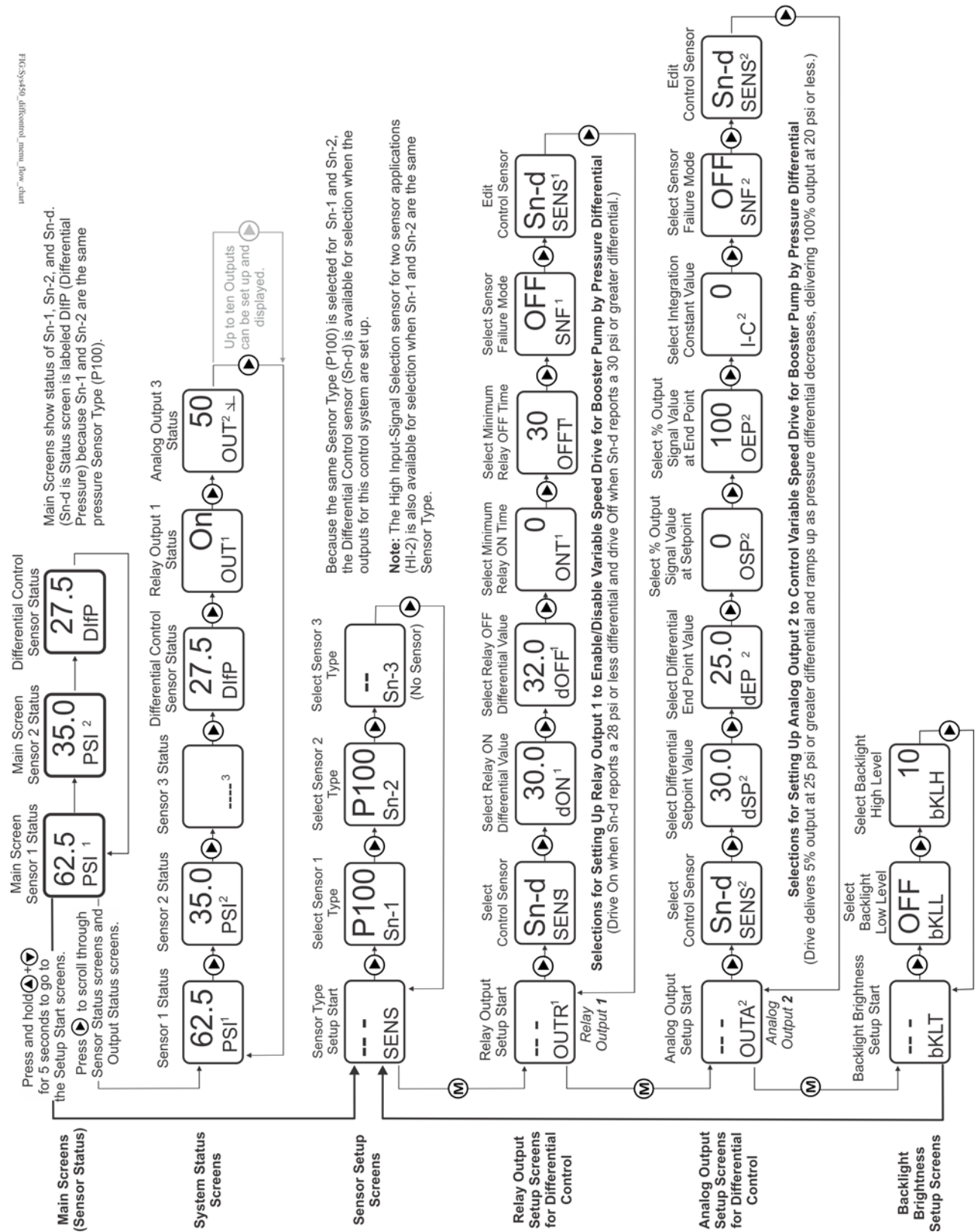

Figure 7: System 450 Status Screens, Setup Screens, and Menu Flow Example for Differential Control



## Technical Specifications

### C450CxN Control Modules with Analog Outputs

<b>Product</b>	<p><b>C450CxN:</b> System 450 Control Modules are sensing controls and operating controls with LCD, four-button touchpad, and On/Off relay output.</p> <p><b>C450CBN-4:</b> Control Module with one SPDT output relay</p> <p><b>C450CCN-4:</b> Control Module with two SPDT output relays</p>									
<b>Supply Power</b>	<p>C450YNN-1 Power Supply Module, or 24 (20-30) VAC Safety Extra-Low Voltage (SELV) (Europe) Class 2 (North America), 50/60 Hz, 10 VA minimum, or 20–30 VDC, 2 Watts minimum for control, then 1 Watt additional for each output attached.</p> <p><b>Note:</b> A System 450 Control Module must only be connected to one power source.</p>									
<b>Ambient Operating Conditions</b>	<p><b>Temperature:</b> -40 to 66°C (-40 to 150°F)</p> <p><b>Humidity:</b> Up to 95% RH Non-condensing; Maximum Dew Point 29°C (85°F)</p>									
<b>Ambient Shipping and Storage Conditions</b>	<p><b>Temperature:</b> -40 to 80°C (-40 to 176°F)</p> <p><b>Humidity:</b> Up to 95% RH Non-condensing; Maximum Dew Point 29°C (85°F)</p>									
<b>Input Signal</b>	0–5 VDC; 1,035 ohms at 25°C (77°F) for an A99 PTC Temperature Sensor									
<b>Output Relay Contacts</b>	<p><b>General:</b> 1/2 HP at 120/240 VAC, SPDT</p> <table border="1"> <tr> <td><b>Specific:</b> AC Motor Ratings</td> <td>120 VAC</td> <td>208/240 VAC</td> </tr> <tr> <td>AC Full-Load Amperes:</td> <td>9.8 A</td> <td>4.9 A</td> </tr> <tr> <td>AC Locked-Rotor Amperes:</td> <td>58.8 A</td> <td>29.4 A</td> </tr> </table> <p>10 Amperes AC Non-Inductive at 24/240 VAC Pilot Duty: 125 VA at 24/240 VAC</p>	<b>Specific:</b> AC Motor Ratings	120 VAC	208/240 VAC	AC Full-Load Amperes:	9.8 A	4.9 A	AC Locked-Rotor Amperes:	58.8 A	29.4 A
<b>Specific:</b> AC Motor Ratings	120 VAC	208/240 VAC								
AC Full-Load Amperes:	9.8 A	4.9 A								
AC Locked-Rotor Amperes:	58.8 A	29.4 A								
<b>Enclosure</b>	Type 1 (NEMA), IP20 High-Impact Thermoplastic									
<b>Dimensions (H x W x D)</b>	127 x 61 x 61 mm (5 x 2-3/8 x 2-3/8 in.)									
<b>Weight</b>	<p><b>C450CBN-4:</b> 209 gm (0.46 lb)</p> <p><b>C450CCN-4:</b> 222 gm (0.49 lb)</p>									
<b>Compliance</b>	<p><b>United States:</b> cULus Listed; UL 60730-1, File E27734; FCC Compliant to CFR47, Part 15, Subpart B, Class B</p> <p><b>Canada:</b> cULus Listed; CAN/CSA-E60730-1, File E27734; Industry Canada (IC) Compliant to Canadian ICES-003, Class B limits</p> <p><b>Europe:</b> CE Mark - Johnson Controls declares that this product is in compliance with the essential requirements and other relevant provisions the EMC Directive.</p> <p><b>Australia and New Zealand:</b> RCM mark, Australia/NZ Emissions Compliant</p>									



The performance specifications are nominal and conform to acceptable industry standards. For application at conditions beyond these specifications, consult Johnson Controls Application Engineering at (414) 524-5535. Johnson Controls shall not be liable for damages resulting from misapplication or misuse of its products.

## North American Emissions Compliance

### United States

This equipment has been tested and found to comply with the limits for a Class B digital device, pursuant to Part 15 of the FCC Rules. These limits are designed to provide reasonable protection against harmful interference in a residential installation. This equipment generates, uses and can radiate radio frequency energy and, if not installed and used in accordance with the instructions, may cause harmful interference to radio communications. However, there is no guarantee that interference will not occur in a particular installation. If this equipment does cause harmful interference to radio or television reception, which can be determined by turning the equipment off and on, the user is encouraged to try to correct the interference by one or more of the following measures:

- Reorient or relocate the receiving antenna.
- Increase the separation between the equipment and receiver.
- Connect the equipment into an outlet on a circuit different from that to which the receiver is connected.
- Consult the dealer or an experienced radio/TV technician for help.

### Canada

This Class (B) digital apparatus meets all the requirements of the Canadian Interference-Causing Equipment Regulations.

Cet appareil numérique de la Classe (B) respecte toutes les exigences du Règlement sur le matériel brouilleur du Canada.

#### European Single Point of Contact:

JOHNSON CONTROLS  
WESTENDHOF 3  
45143 ESSEN  
GERMANY

#### NA/SA Single Point of Contact:

JOHNSON CONTROLS  
507 E MICHIGAN ST  
MILWAUKEE WI 53202  
USA

#### APAC Single Point of Contact:

JOHNSON CONTROLS  
C/O CONTROLS PRODUCT  
MANAGEMENT  
NO. 22 BLOCK D NEW DISTRICT  
WUXI JIANGSU PROVINCE 214142  
CHINA

#### European Single Point of Contact:

JOHNSON CONTROLS  
WESTENDHOF 3  
45143 ESSEN  
GERMANY

#### NA/SA Single Point of Contact:

JOHNSON CONTROLS  
507 E MICHIGAN ST  
MILWAUKEE WI 53202  
USA

#### APAC Single Point of Contact:

JOHNSON CONTROLS  
C/O CONTROLS PRODUCT MANAGEMENT  
NO. 22 BLOCK D NEW DISTRICT  
WUXI JIANGSU PROVINCE 214142  
CHINA



[www.penncontrols.com](http://www.penncontrols.com)

*® Johnson Controls and PENN are registered trademarks of Johnson Controls in the United States of America and/or other countries. All other trademarks used herein are the property of their respective owners. © Copyright 2018 by Johnson Controls. All rights reserved.*